

UNIT
GROUND
LUG



FACTORY WIRE ———
FIELD WIRE - - - - -

STANDARD COMPONENTS LEGEND:

- BM - BLOWER MOTOR
- CAP - COMPRESSOR CAPACITOR
- CC - COMPRESSOR CONTACTOR
- CCH - CRANKCS HTR (WHEN SUPPLIED)
- EOVD - EXTERNAL OVERLOAD (NOTE 5)
- HPS - HIGH PRESSURE SWITCH
- LPS - LOW PRESSURE SWITCH
- PTCR - POS TEMP COEFF RESISTOR (WHEN SUPPLIED)
- PITB - POWER INTERCONNECT TBLK
- RV - REVERSING VLV (HEAT PUMPS)

OPTIONAL COMPONENTS LEGEND:

- [] AUX - AUXILLIARY RELAY (FOR LOOP PUMP, ETC.)
- [] CBR - 24V CRCT BRKR (75VA ONLY)
- [] CMFR - COMPR MALFUNCTION RELAY
- [] CMR - COMPR MONITOR RELAY
- [] CS - CONDENSATE SENSOR INSTALLED
- [] EMS - ENERGY MGMNT SYSTEM RELAY
- [] FS - FREEZE SENSOR INSTALLED (NOTE 10)
- [] GLP - GROUND LOOP PUMP
- [] HP - HP SERIES ELECTRIC HTR PKG (SEE HEATER DIAGRAM)
- [] HRP - HEAT RECOVERY PACKAGE, INCLUDES:
- [] HRP - HEAT RECOVERY PUMP MOTOR
- [] HWL - HOT WATER LIMIT (140 DEG)
- [] SWT - ON/OFF SWITCH AND OVERLOAD PROTECTION

NOTES:

1. SEE UNIT NAME PLATE FOR ELECTRICAL RATING
2. ALL FIELD WIRING MUST BE IN ACCORDANCE WITH N.E.C.-N.F.P.A. #70
3. 208/230V UNITS ARE FACTORY WIRED FOR 230V OPERATION. FOR 208V OPERATION, REMOVE ORG LEAD AND REPLACE WITH RED LEAD. CAP ALL UNUSED LEADS
4. PTCR IS STANDARD ON SELECT UNITS.
5. EXTERNAL OVERLOAD STANDARD ON ALL UNITS EQUIPPED WITH ROTARY COMPRESSORS.
6. FOR ALTERNATE EMS COIL VOLTAGES CONSULT FACTORY.
7. REMOVE JUMPER WIRES FROM BETWEEN CONTACTOR LINE SIDE AND POWER INTERCONNECT TBLK WHEN ELECTRIC HEAT IS INSTALLED. CONNECT PITB TO POWER TBLK IN HEATER CONTROL BOX.
8. UPM-I INCLUDES BUILT IN:
 - 30-60 SECOND RANDOM START
 - 5 MINUTE DELAY ON BREAK
 - 90 SECOND LOW PRESSURE BYPASS
9. SETTING THE TEST MODE JUMPER ON UPM-I TO YES REDUCES ALL TIME DELAYS TO 5 SECONDS.
10. "FREEZE" PINS ON UPM MUST BE JUMPED TOGETHER IF FREEZE SENSOR IS NOT INSTALLED.
11. BLINK CODES FOR HARD LOCK OUT:
 - 1 - HIGH PRESSURE FAULT
 - 2 - LOW PRESSURE FAULT
 - 3 - FREEZE FAULT
 - 4 - CONDENSATE FAULT

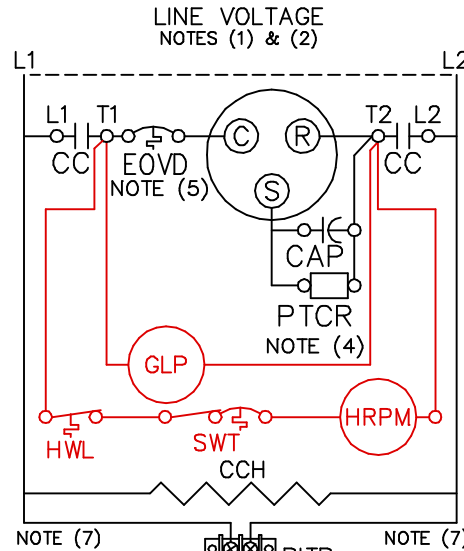

NOTE (7)

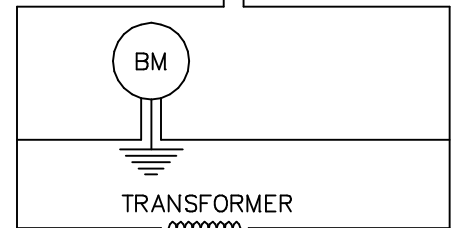

BLK (COM) RED (208)
ORG (240)
NOTE (3)

TO ELECTRIC HEATER CONTROL BOX
WHEN ELECTRIC HEAT IS INSTALLED

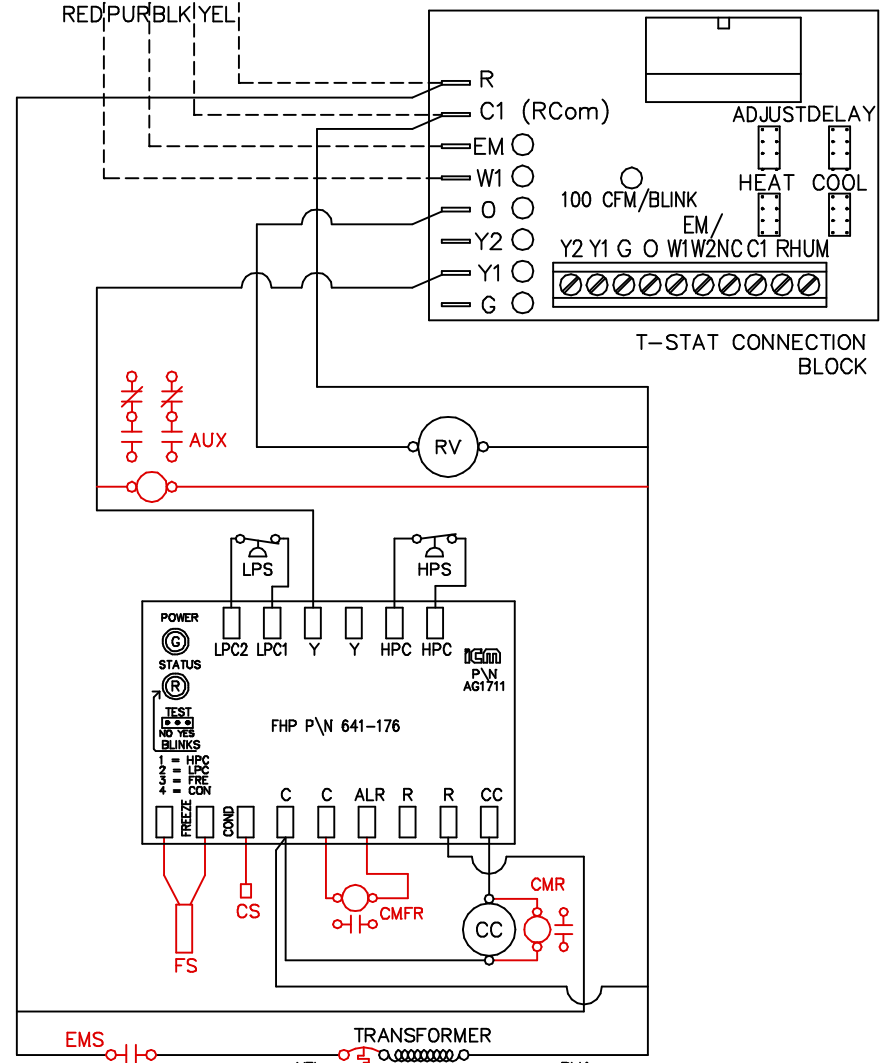

NOTE (6)
24VAC BY OTHERS

WIRING DIAGRAM - 208/230V - 1PH - 60HZ SINGLE PHASE DIRECT DRIVE ECM BLOWER MOTOR				
SINGLE STAGE WITH INTERNAL ELECTRIC HEAT 1-1/2 THROUGH 6 TON CAPACITY WITH UPM-I				
SIZE	CSSN.	DWG NO.	DRAWN BY	REV
	GS111002	GS111002	RKS	0
SCALE				DATE 10-15-02